

The Orcam GPS02F is a compact, low cost, low power OEM GPS receiver based on the MTK 32 channel GPS receiver chip architecture.

With a tracking sensitivity of -158 dBm, the GPS02F will continue tracking in the most demanding environments making indoor navigation possible and meeting the challenges of urban canyons and multi path environments.

Differential GPS

GPS02 supports D-GPS, either SBAS (WAAS, EGNOS, MSAS) or by RTCM protocol on serial port B.

Up to 5 Hz position update rate

GPS02F as standard is available with either 1 Hz or 5 Hz position update rate. A 5 Hz update rate will support higher speed applications and also make it possible for the user to apply signal processing to improve position accuracy, and reduce the "wander" present in all stationary GPS receivers.

Power Supply

GPS02F accepts supply voltages from 3.0 to 5.5 V DC and has all necessary power regulation and -management functions on board. There is also provision for a separate battery backup voltage (VBAT) between 1.8 - 5.0 V DC to retain information stored in the receiver RAM and to maintain the Real Time Clock running in the receiver.

VBAT must be powered at all times to prevent loss of navigation data when VCC is removed.

Power consumption is less than 145 mW during tracking when supplied from 3.3 V DC, making it possible to embed into portable battery powered applications.

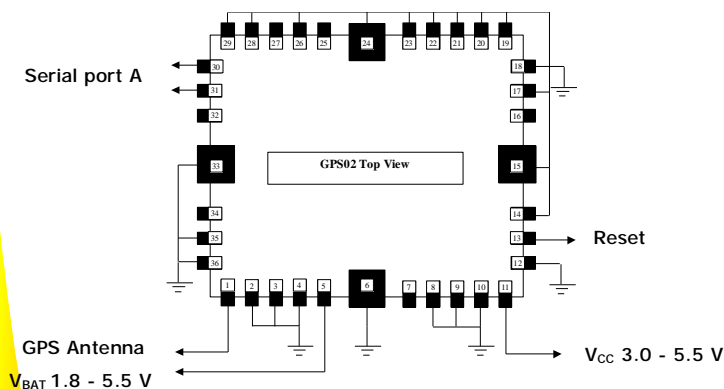

Simple connection diagram for GPS02

For detailed pin-out and dimensions please see the GPS02 Data Sheet & Integration guide

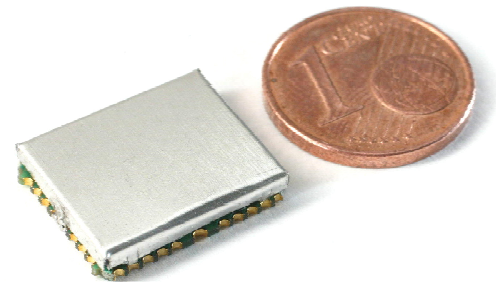

- 32 channel L1 receiver at 1575.42 Mhz
- On-board LNA & SAW-filter
- NMEA 0183 Protocol on port A
- Supports SBAS and RTCM differential corrections
- 3,0 - 5,5 V operation
 - < 60 mA @ 3.3 V acquisition
 - < 44 mA @ 3.3 V tracking
 - ~ 60 µA from back-up battery when VCC is removed.

Acquisition performance

- w Hot Start: < 1 s typ.
- w Warm Start: < 33 s typ.
- w Cold Start: < 36 s typ.
- w Sensitivity

Tracking: -158 dBm
Cold Start: -146 dBm
Reacquisition: -156 dBm

Recommended Antenna

External active GPS Antenna with min +15 dBi gain. Passive antenna may be used if antenna cable length is short, but may result in some performance degradation.

Ordering information

Part no	Position update rate	Serial Protocol Default Baudrate
GPS02F1	1 Hz	NMEA 9800 Baud
GPS02F5	5 Hz	NMEA 19200 Baud

Orcam GPS02F

32 channel OEM GPS receiver



Electrical Specifications

General Characteristics	Receiver Architecture	32 Channels, 1 satellite /channel simultaneous L1 1575.42 MHz, C/A Code 1.023 MHz chip rate 1 Hz (GPS02F1) or 5 Hz (GPS02F5)
	Update rate	
	Antenna	External active GPS antenna with +15 dBi gain, passive GPS antenna can be used but with some reduction of performance.
Performance Characteristics	Processor	ARM7 / TDMI
	Position Accuracy	approx. 3 meters CEP 50 % of the time
	Sensitivity	
	- Cold Start - Reacquisition - Tracking	- 146 dBm - 156 dBm - 158 dBm
Communications	Acquisition Rate	< 36 s Cold start, open sky (typical) < 33 s Warm start, open sky (typical) < 1 s Hot start & reacquisition (typical)
	Serial Port Navigation message protocol	Twp Serial Ports, 3 V logic NMEA-0183, v3.01 at 4800, 14400, 9600, 19200, 38400, 57600 or 115200 Baud on serial port A RTCM SC-104 on serial port B 3 V CMOS logic levels
	D-GPS protocol Digital I/O	
Power Supply	NMEA default output messages Update rate & baud rate	GGA, GSA, GSV, RMC and VTG GPS02F1: 1 Hz, 9600 baud, GPS02F5: 5Hz, 19200 baud
	Main power input, V _{CC} Supply current	3,0 - 5,5 V DC Acquiring: < 60 mA @ 3.3 V, < 61 mA @ 5.5 V Tracking: < 44 mA @ 3.3 V, < 45 mA @ 5.5 V
	Battery Backup Battery current drain	1.8 - 5.5 VDC ~ 60 µA

Environmental Specifications

Operating temp.	-30 to +85 °C
Storage temp.	-45 to +125 °C
Altitude	18 000 meters (60 000 feet) max.
Velocity	515 meters /second max.
Acceleration	4 g max.

Dimensional Drawing & Recommended pad layout

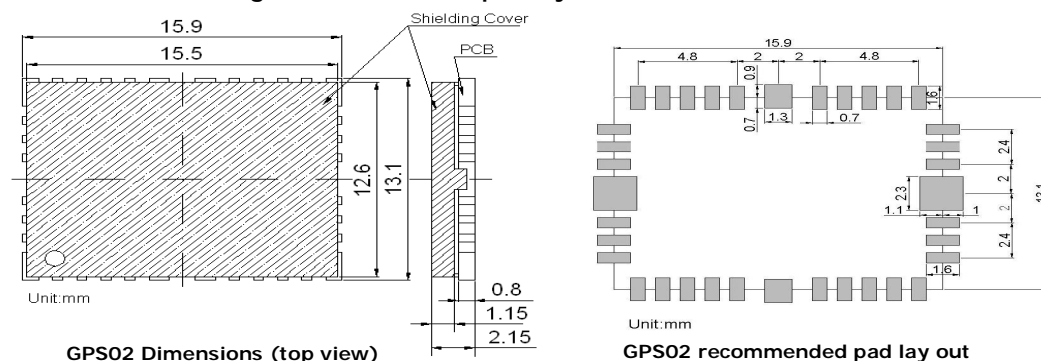

For further information visit www.orcam.eu for a list of our local representatives in:
 Belgium - Bulgaria - Czech Republic - Denmark - Finland - France - Germany - Hungary - Israel - Italy
 Netherlands - Norway - Poland - Portugal - Romania - Russia - Slovakia - Slovenia - South Africa - Spain
 - Sweden - Ukraine - United Kingdom

Orcam Systems AB

Gesällgatan 2 C, P.O. Box 833, SE - 745 26 Enköping, Sweden
 Phone: +46 - (0)171 447 420, Fax: +46 - (0)171 299 70
 Mail: gps@orcama.eu, Web: www.orcam.eu